

Contents

Chapter 1. Overview and Main Feature	2
1-1. Overview.....	2
1-2. Part Layout.....	2
1-3. Main Feature.....	3
Chapter 2. Hardware Detail	4
2-1 Schematic.....	4
2-2 Physical Dimension.....	5
2-3 Circuit Diagram.....	6
2-4 Electric Characters	8
2-5 Port Definition	8
2-5-1. 7-segment LED.....	8
2-5-2. Shift Register Data Driver.....	9
2-5-3. Data Ports Definition	9
2-5-4. Auxiliary Power Port.....	9
2-5-5. Data Buffer	10
Chapter 3. Sample Codes	11
3-1. LED Segment Drive Demo Board's Schematic.....	11
3-2. How to Connect Load.....	11
3-3. How to display data with PIC10F200 and PICC8.05 environment	12
Chapter 4. Contact US	15

Chapter 1. Overview and Main Feature

4 digits 7segment panels are manufactured by Sure Electronics. This series includes 5 different size panels, they are 1.5inches, 1.8inches, 2.3inches, and 4inches, 7inches (character height). All those panels are driven by SPI like interface and all work in full static mode. They are easy to be interfaced to any Microcontrollers. They could be widely used in panel meters, big clocks and any other information display usage.

Sure Electronics provides series of such information boards which are supposed to reduce your development time and make them standard. In this series, most boards are 4 digits and static, if customer need any special digits and special size ones, could contact us with the contact information at the end of this document. The 7 inch character height one is 1digit/board.

This document is used to describe how to use 1.5inches character height panels.

1-1. Overview

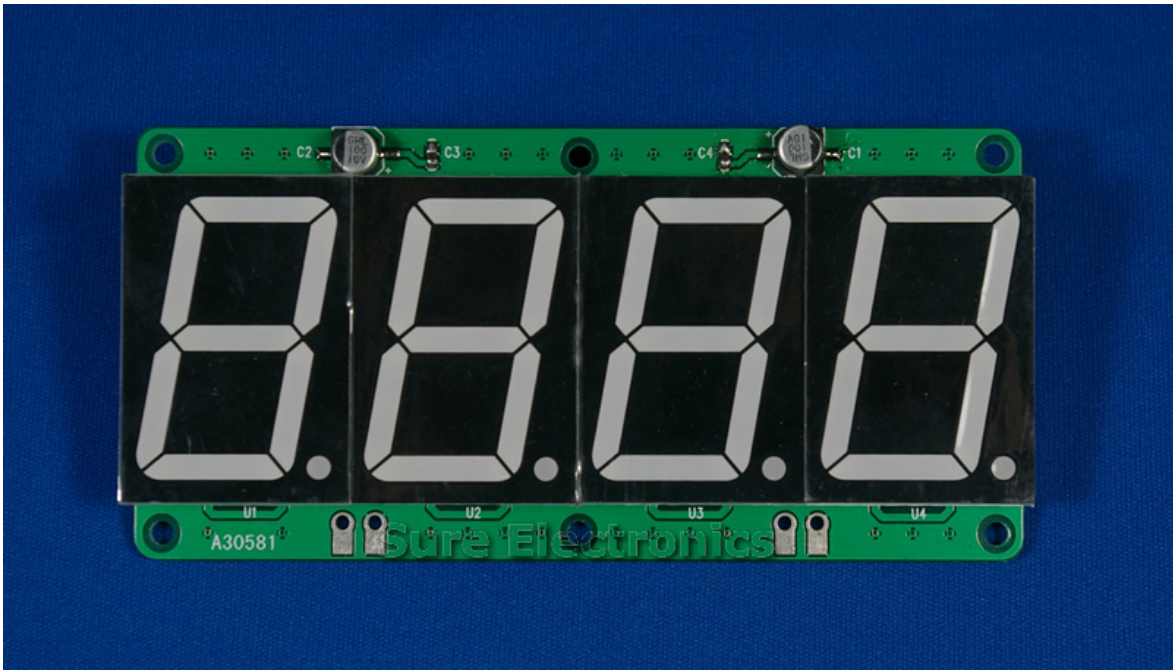

Figure 1

1-2. Part Layout

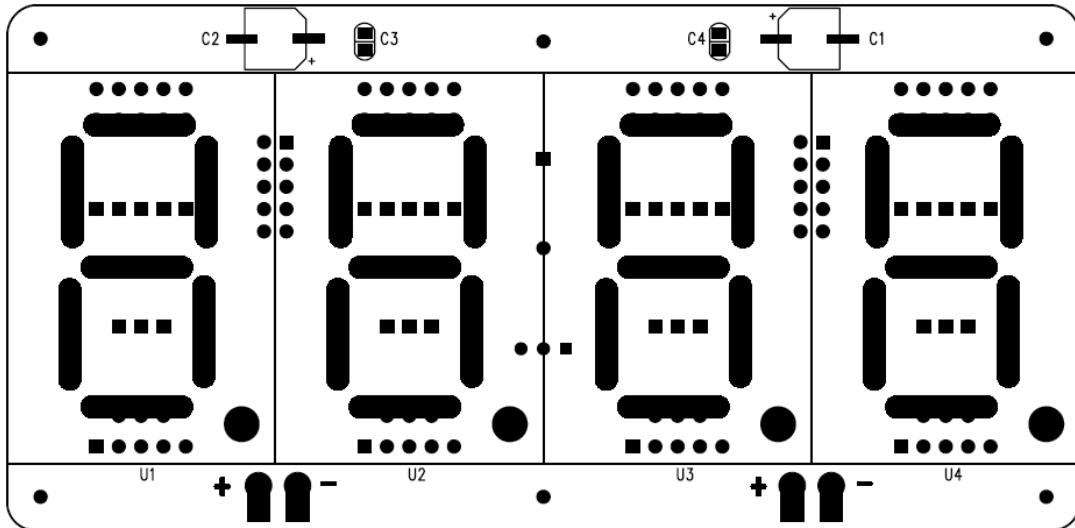

Figure 2 Top Part Layout

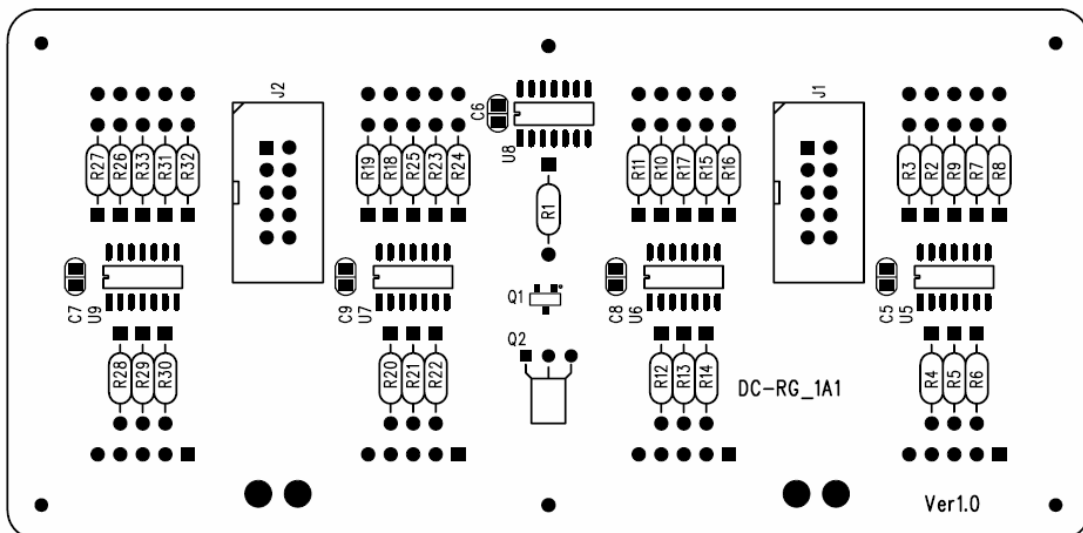

Figure 3 Bottom Part Layout

1-3. Main Feature

1-3-1. 4 digits 7-segment 1.5inches LEDs are installed on this panel, those segments are common cathode type.

1-3-2. 2*10pin interface for power serializing and data transferring, data inputs from J1 and flows out from J2.

1-3-3. A 74HC00 Nand chip is used to buffer CLK_IN and DIMM_IN control signal.

1-3-4. LED driver chips are composed of 4pcs of 74HC164, they are serialized to each other, the first chip receives data from Microcontroller or the board ahead, the final chip shifts data to next boards. Data should be clocked in from CLK_IN and DATA_IN in J1, and DIMM_IN pin should be pull to high to enable display.

2-2 Physical Dimension

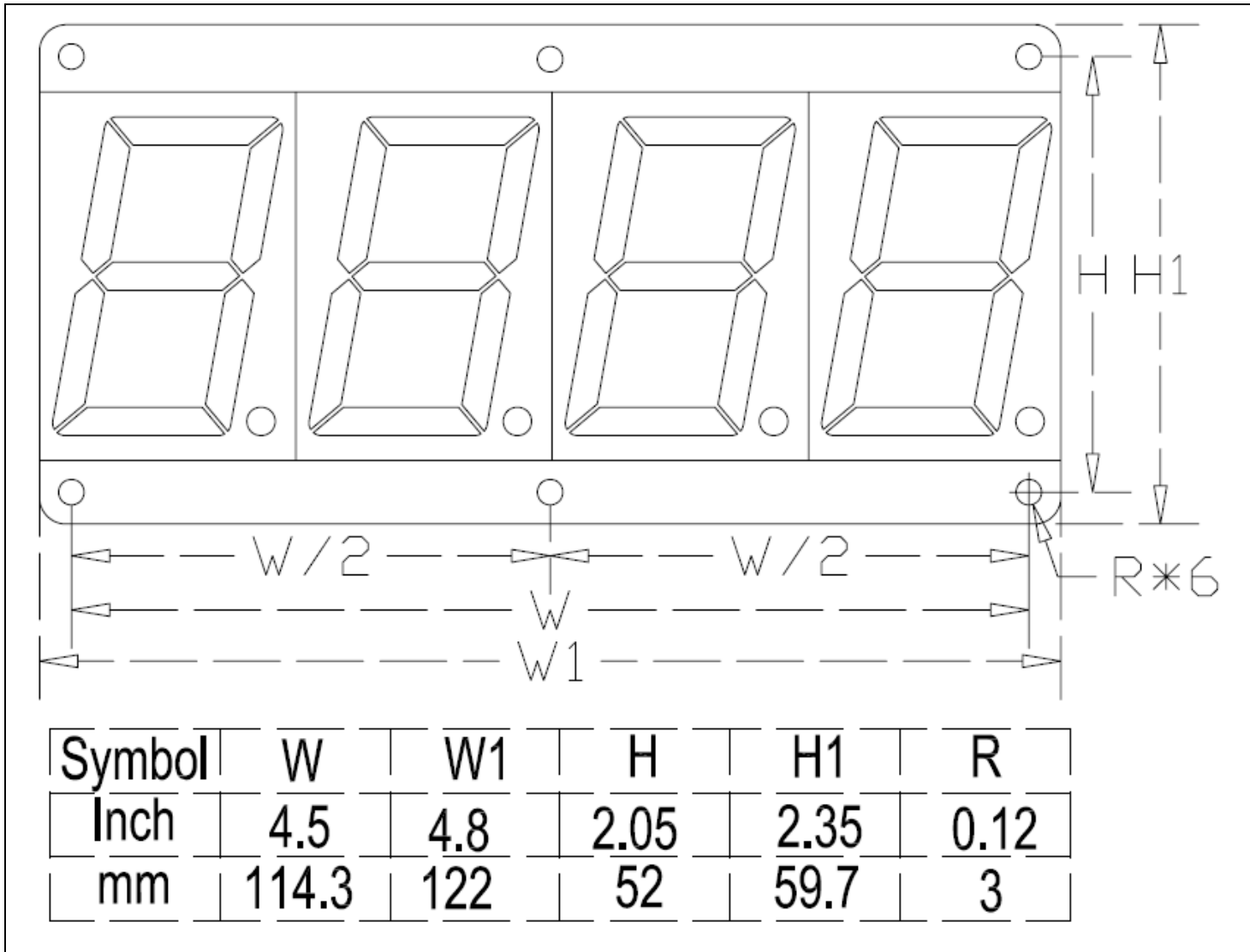

Figure 5

2-3 Circuit Diagram

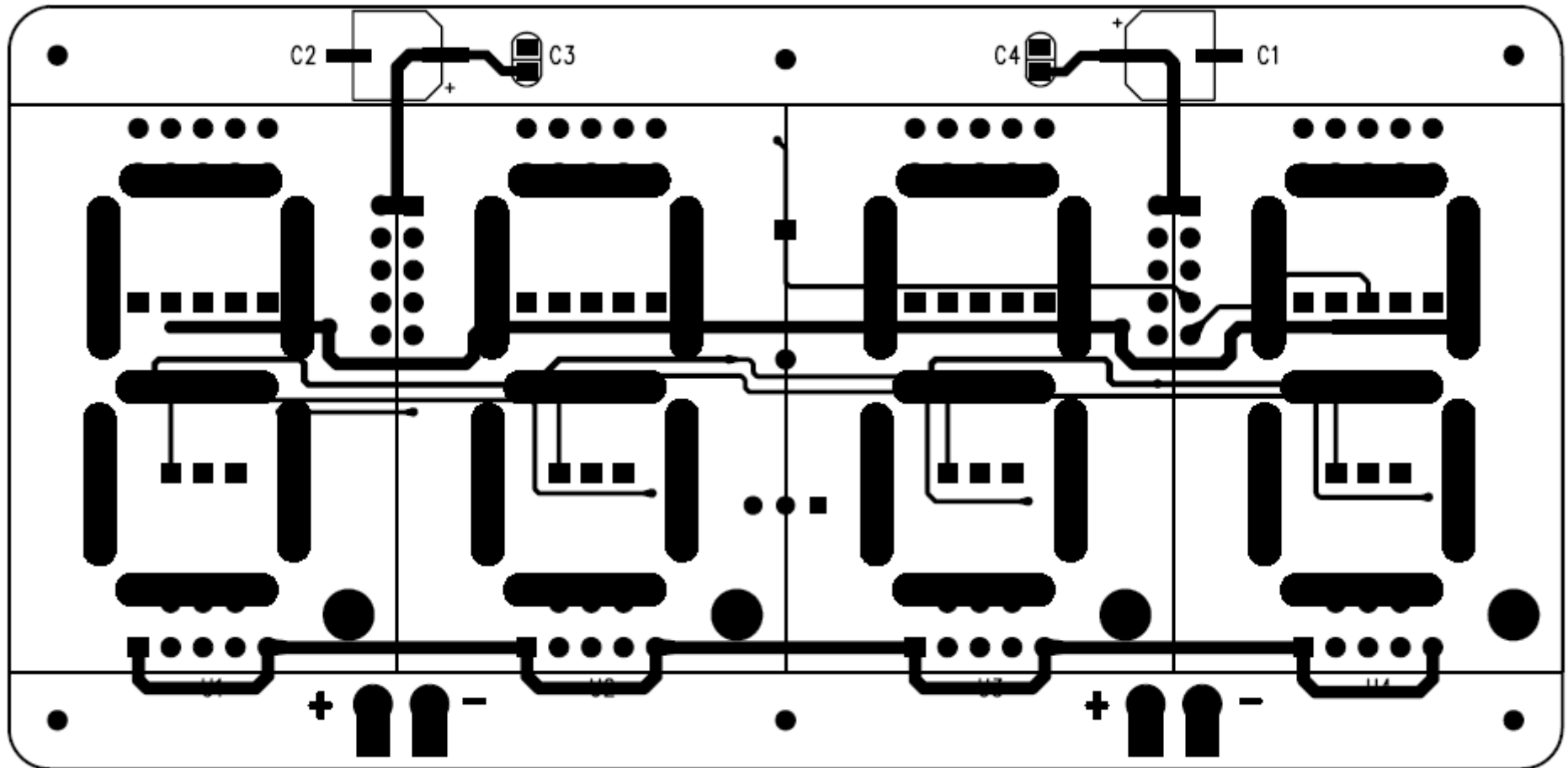

Figure 6

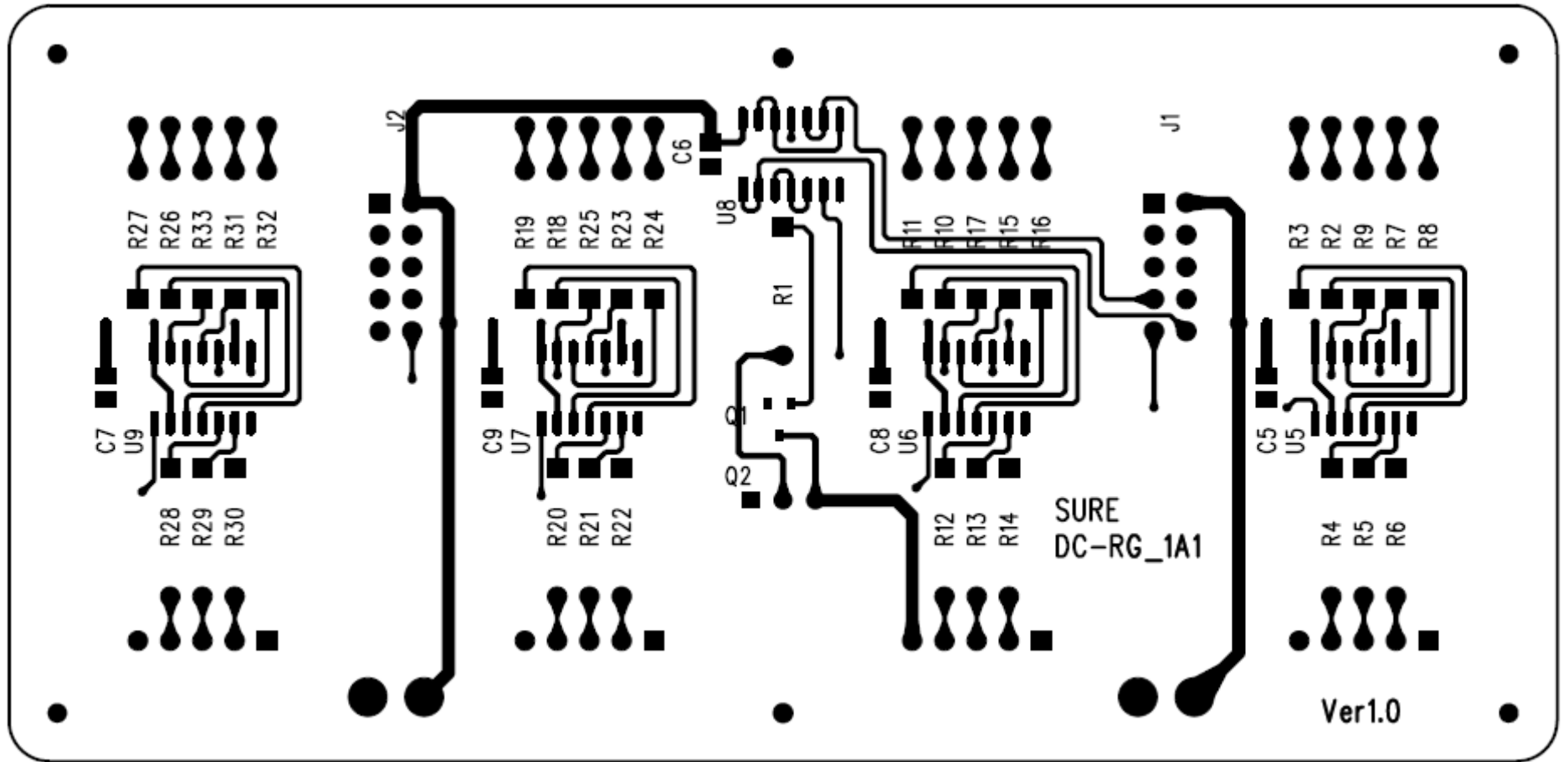

Figure 7

2-4 Electric Characters

- Power Supply: DC4V-5.5V 0.2A/pcs (Maximum), for each additional panel, add another 0.2A, if voltage is less than 4V, the brightness would not be enough.
- For over 4 panels, user must add auxiliary power on the auxiliary power, or the 10pin communication port could not carry so much current.
- Maximum clock freq: 1MHz, 4 boards serialized
100kHz, 20 boards serialized
- If the communication speed is too high, it may cause communication problems.
- Suggested Refresh Rate: Less than 10Hz if DIMM is not used. Less than 50Hz if DIMM is used.
- Drive Current/segment: 10mA +3mA/-2mA, this value may be changed based on the production batch, and the dot uses different current.
- Drive Method: Fully static.
- Connection Method: 74HC164 in series, SPI like interface.
- Maximum Cascade Level: 20 boards in series, clock less than 100kHz.
- Interface Voltage Level: $VDD \cdot 0.8 - VDD + 0.5V$, standard CMOS level. If you need TTL/CMOS compatible interface in batch, please contact us but the quantity should be no less than 100pcs.

2-5 Port Definition

2-5-1. 7-segment LED

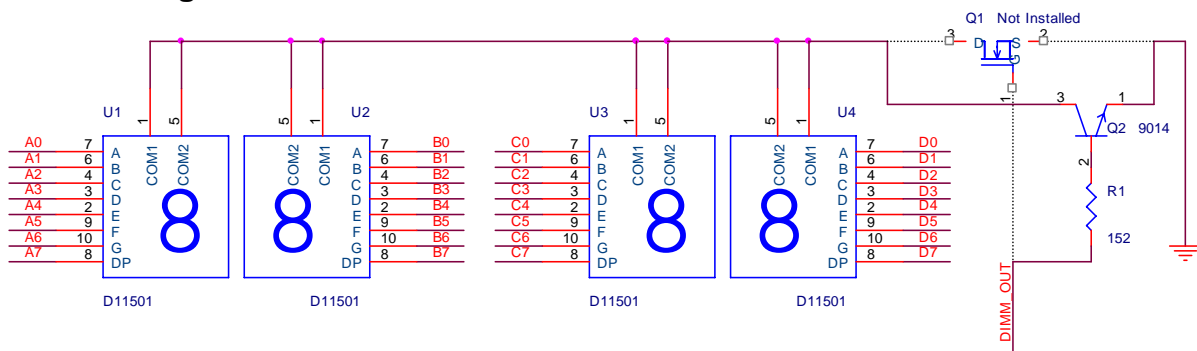

Figure 8

4 Digits of 1.5 inches, common cathode, high brightness red 7-segment LEDs are installed on this board. They are marked as U1-4. DIMM_OUT signal is for brightness control usage, you could add simple on/off or PWM signal on this signal, when this signal is set to high, all segments will light on if valid data is shifted out from the 74HC164 chip. If you are changing the data in the 74HC164 driven chip, set this pin to low then the hash signal will not affect the display. Of course if you want to adjust the brightness of those LEDs, PWM signal could

be applied on the DIMM_IN pin. It is buffered with a 74HC00, and DIMM_OUT signal will drive this board and next.

2-5-2. Shift Register Data Driver

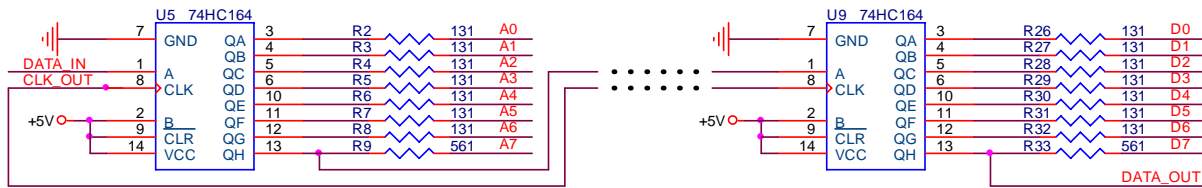

Figure 9

74HC164 is used as shift register in this board. They are U5, U6, U7, and U9 and connected to U1-4. CLK_OUT is driven by a buffered output from CLK_IN with 74HC00. DATA_IN is data input pin of the first 74HC164, then all 74HC164 of cascaded boards will be serialized. All those pins accept only CMOS signals. Once you clock in correct data through these 2 pins, and ensure that PWM signal or ON/OFF signal is applied correctly on the DIMM_IN pin, the board will begin display.

Correspondence between Character Codes and Character Patterns:

Character Patterns	0	1	2	3	4	5	6	7	8	9
Character Codes	0xfc	0x60	0xda	0xf2	0x66	0xb6	0xbe	0xe0	0xfe	0xf6
Character Patterns	a	b	c	d	E	f	g	h	i	j
Character Codes	0xee	0x3e	0x1a	0x7a	0x9e	0x8e	0xf6	0x6e	0x60	0x70
Character Patterns	l	n	o	p	Q	r	s	t	u	y
Character Codes	0x1c	0x2a	0x3a	0xce	0xe6	0x0a	0xb6	0xe0	0x38	0x76

Figure 10

2-5-3. Data Ports Definition

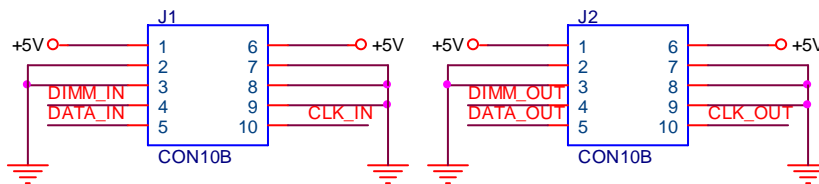

Figure 11

2 IDC sockets are located on the board. They are data input and output interface, marked as J1 and J2. The definition is shown in Figure 11. When the board is working separately, connect J1 to the Microcontroller board and leave J2 open. If lots of same boards are in series, connect next board's input to previous one's output. Then you could connect up to 20 boards in series. Notice if over 4pcs of such boards are serialized, you must add auxiliary power cable to some boards to enhance the current transfer.

2-5-4. Auxiliary Power Port

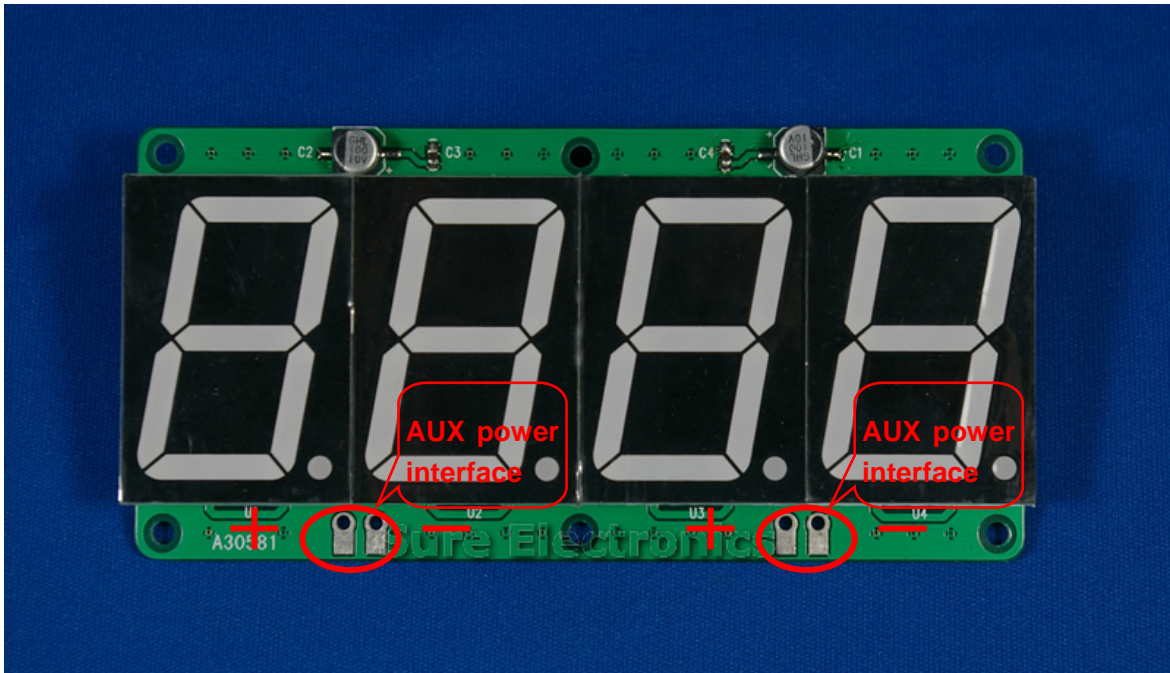

Figure 12

There are 2 auxiliary power ports on this board. If you use less than 4pcs of such boards in series, you could simply use a 10pin IDC flat cable to connect those boards. But if over 4 boards connected together, you must add additional power supply to some of those boards, or the current may be lacking. Just apply +5V to some boards on the AUX power port. And be sure the polarity is correct.

2-5-5. Data Buffer

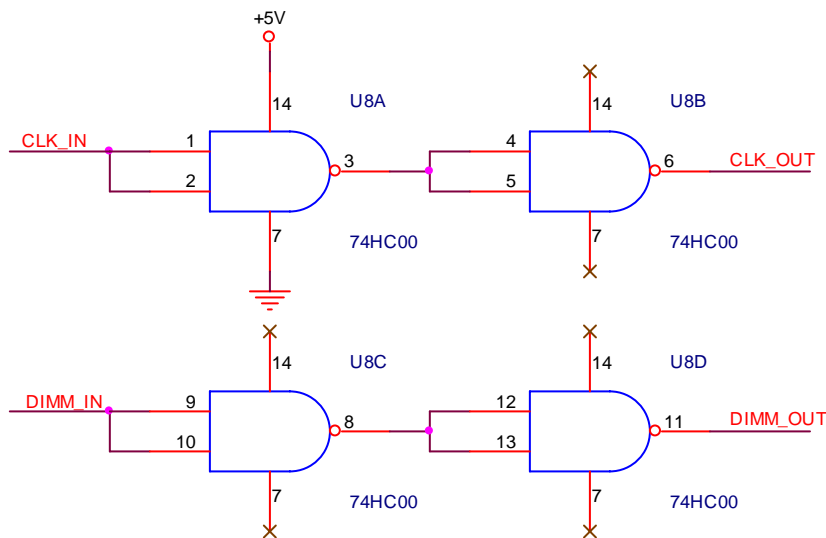

Figure 13

74HC00 chip is used to buffer Clock and DIMM signal in this board. A CMOS chip is not able to drive over 10pcs CMOS input if the cable is so long, here 74HC00 is used as NOT gate, and 2 gates in series is a buffer.

Output Voltage	Encoder Position Setting(1)(2)	
5V		
12V		
0V		

Notice:

- (1) DIP switch only has the 3 ways as shown above to work; any other switching ways are prohibited.
- (2) Users shouldn't change the voltage while LED Segment Drive Demo Board is working. It is only allowed to change it before applying the current.

3-3. How to display data with PIC10F200 and PICC8.05 environment

Source code is shown below,

```
#include <pic.h>

__CONFIG(UNPROTECT&MCLRDIS&WDTDIS); //Configure Word

#define Fuc_key    GP3
#define DIMM       GP2
#define CLK        GP1
#define DATA      GP0

unsigned char disp_data;
unsigned char key_pressed,last_key_pressed;
unsigned char Value;
unsigned char time;

//The total of cathode
const unsigned char Digital_TAB[] = {0xff,0xfc,0x60,0xda,0xf2,0x66,0xb6,0xbe,0xe0,0xfe,0xf6,
                                     0x80,0x40,0x20,0x10,0x08,0x04,0x02,0x01};

void change(void);
void LED_data(void);
void LED_display(void);

void delay_2ms(void)
{
    unsigned char i, j, k;
```

```
for(i = 0; i < 5; i++)
{
    for(j = 0; j < 200; j++)
        k--;
}

void change(void)
{
    key_pressed=Fuc_key;
    if((key_pressed==0)&(last_key_pressed==1))
    {
        delay_2ms();
        if(key_pressed==0)
        {
            disp_data++;
            if(disp_data==19)disp_data=0;
        }
    }
    last_key_pressed=key_pressed;
}

void LED_data(void)
{
    unsigned char i;

    for(i = 0; i <19; i++)
    {
        if(i==disp_data){Value = Digital_TAB[i];}
    }
}

void LED_display(void)
{
    unsigned char i;
    unsigned char U;

    U=Value;
    for(i = 0;i < 8; i++)
    {
        DATA = U & 0x01;
        CLK = 0;
        CLK = 1;
        U = U>>1;
    }
    U=Value;
    for(i = 0;i < 8; i++)
    {
        DATA = U & 0x01;
        CLK = 0;
        CLK = 1;
        U = U>>1;
    }
    U=Value;
    for(i = 0;i < 8; i++)
    {
        DATA = U & 0x01;
```

```
        CLK = 0;
        CLK = 1;
        U = U>>1;
    }
    U=Value;
    for(i = 0;i < 8; i++)
    {
        DATA = U & 0x01;
        CLK = 0;
        CLK = 1;
        U = U>>1;
    }
}

void main(void)
{
    OSCCAL=0;
    TRIS = 0b11111000;
    OPTION=0b10011111;

    while(1)
    {
        change();
        LED_data();
        DIMM = 0;
        LED_display();
        DIMM = 1;           //Active-high Output Enable

        delay_2ms();
    }
}
```

Chapter 4. Contact US

Sure Electronics Co., Ltd.

Floor 5, A zone,
Qinhuai Technology Innovation center,
NO.105-2, DaMing Road,
Nanjing,
China

Tel: +8613601408832
+86-25-66606340

(English service, from GMT1-10AM, only for technical questions)

Email: support@sure-electronics.net

Website: www.sure-electronics.net
www.sure-electronics.com
www.sureelectronics.net